

自動車

Automobile

コンパクトカーから電気自動車まで
車づくりのすみずみに
 We Support Auto Industry

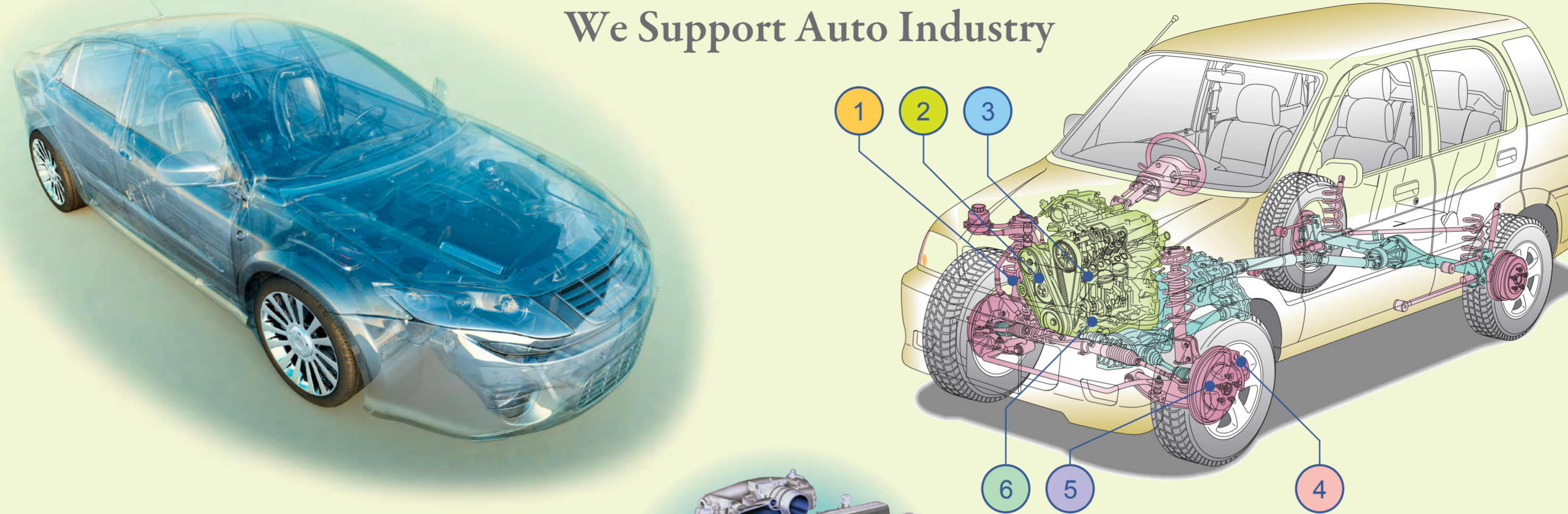

1 CVT式自動変速機

Continuously Variable Transmission

Hyper CVT

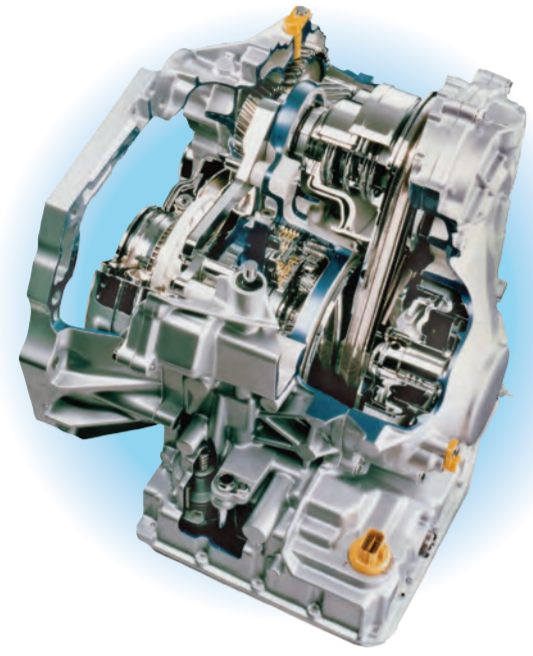
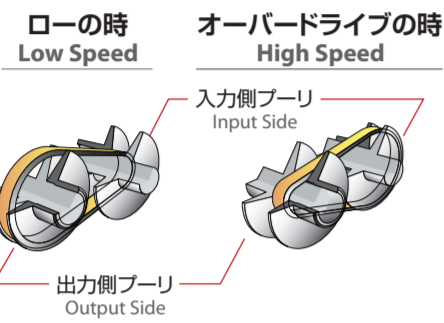

CVT プーリ
CVT Pulley

複合研削盤
Special Purpose Multi-Head
Grinding Machine

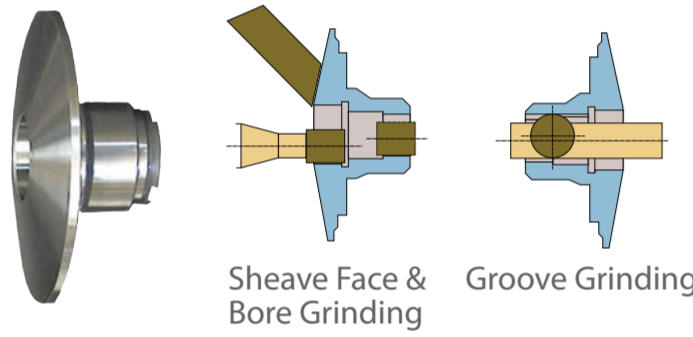

2 エンジン

Engines

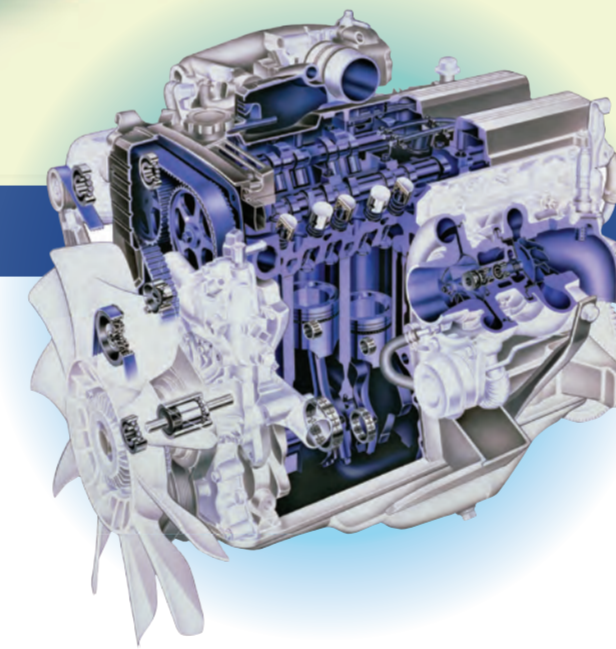

シリンダヘッド
Cylinder Head

シリンダブロック
Cylinder Block

シリンダライナ
Cylinder Liner

コンロッド
Connecting Rod

エンジンバルブ
Engine Valve

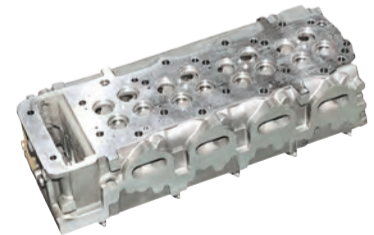

バルブシート
Valve Seat

リフターバルブ
Lifter Valve

ロッカーアーム
Rocker Arm



プラネタリー形平面研削盤
Planetary Surface
Grinding Machine

心なし研削盤
Centerless
Grinding Machine

平面研削盤
Surface
Grinding Machine



PVT2

6015C

RV2

C3510

HD5

KC300

HD3

3 オイルポンプ

Oil Pump

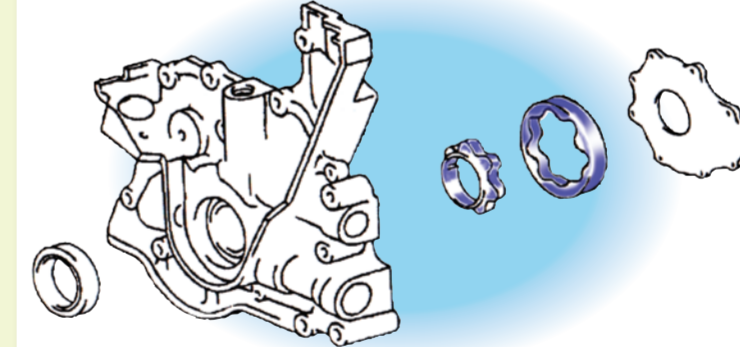

アウター&インナー
Outer Ring & Inner Ring



対向二軸平面研削盤
Double Disc Surface
Grinding Machine

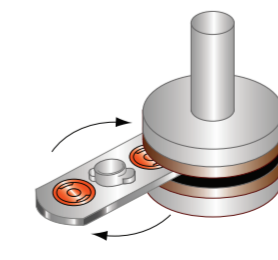

KVD350

6 カークーラー用コンプレッサ

Compressor

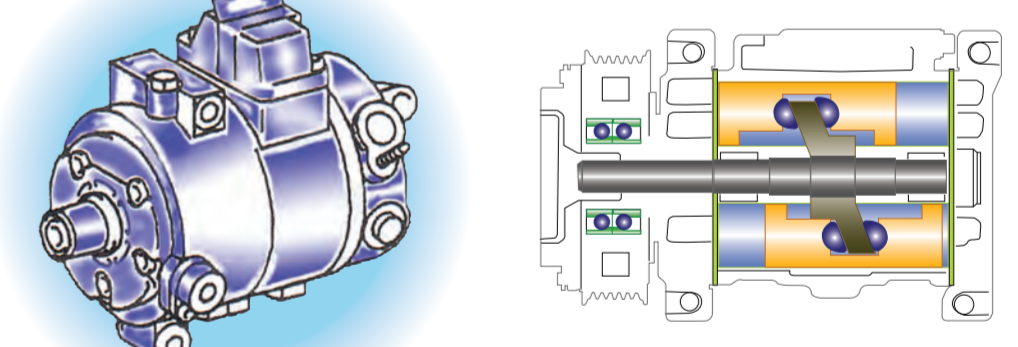

ピストン
Piston

シャフト
Shaft

斜板
Axial Plate



心なし研削盤
Centerless
Grinding Machine



対向二軸平面研削盤
Double Disc Surface
Grinding Machine

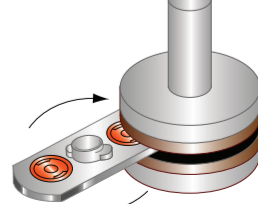

C6030

KVD350

4 ディスクブレーキ

Disc Brake Unit

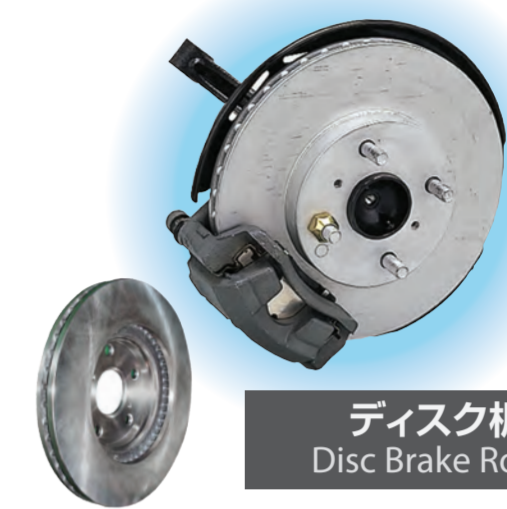

ディスク板
Disc Brake Rotor

対向二軸平面研削盤
Double Disc Surface
Grinding Machine
(Horizontal Spindle Type)



HD5

5 前輪車輪HUBユニット

HUB Unit

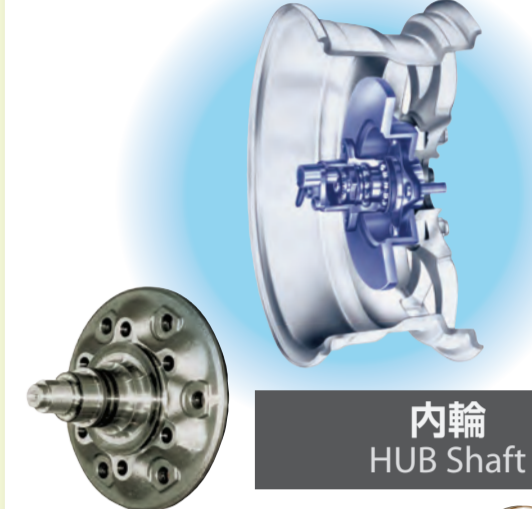

内輪
HUB Shaft

軸受溝研削盤
Race Way Grinding
Machine



3RG510